



## Aquadis+

### A New Standard for Volumetric Water Meters



#### > Long-term performance

- Long-lasting high accuracy
- High Efficiency
- Any installation position
- Permanent Readability

#### > New Design Features

- Enhanced Robustness
- Pre-equipped for Communication
- Compact
- Easy Handling

Aquadis+ is a world-class piston type volumetric water meter, designed for the best metering and billing in residential applications.

#### Efficiency

Focusing on reliable and long-term performance, Aquadis+ offers maximised revenue collection provided by an innovative design to maintain high efficiency over time.

#### The Technology

The working principle of Aquadis+ is based on the combination of an extra dry register (no gears in the water), associated with a hermetical measuring element, using the concept of magnetic transmission.

#### Communication Device

Pre-equipped for future communication through Cyble.

#### Approvals and Standards

Aquadis+ is approved at Q3 1,6, 2,5 and 4m<sup>3</sup>/h from Ratio 50 to 400 according with:

- MID, Directive 2004/22/EC of the European Parliament
- European Standard EN14154 - 2005
- International Standard ISO 4064
- Recommendations OIML R49

Aquadis+ is also approved class C and D from Qn 0.75 to 1.5 according with:

- > European Directive EEC 75/33 for cold potable water meters
- > British Standard BS 5728

Aquadis+ is compliant with regulations for products to use in contact with water intended for human consumption. Aquadis+ has approvals granted by the following laboratories:

- > ACS (France)
- > Belgaqua (Belgium)
- > Kiwa (Netherlands)
- > WRAS (United Kingdom)

**Hermetically Sealed Register\* (Counter)**

Glass lens and copper can register, condensation and water proof (IP 68), allows permanent readability

\* option for plastic case, for specific applications



**Communication**

Pre-equipped with the proven Cyble target allowing the meter's integration into remote reading systems by adding the relevant module



**Robust Case (available also in thermoplastic material)**

High resistance to pressure

**Effective and Easy Maintenance Filter**

Prepared to contain major particles, easy to clean

**Compact and Easy Handling**

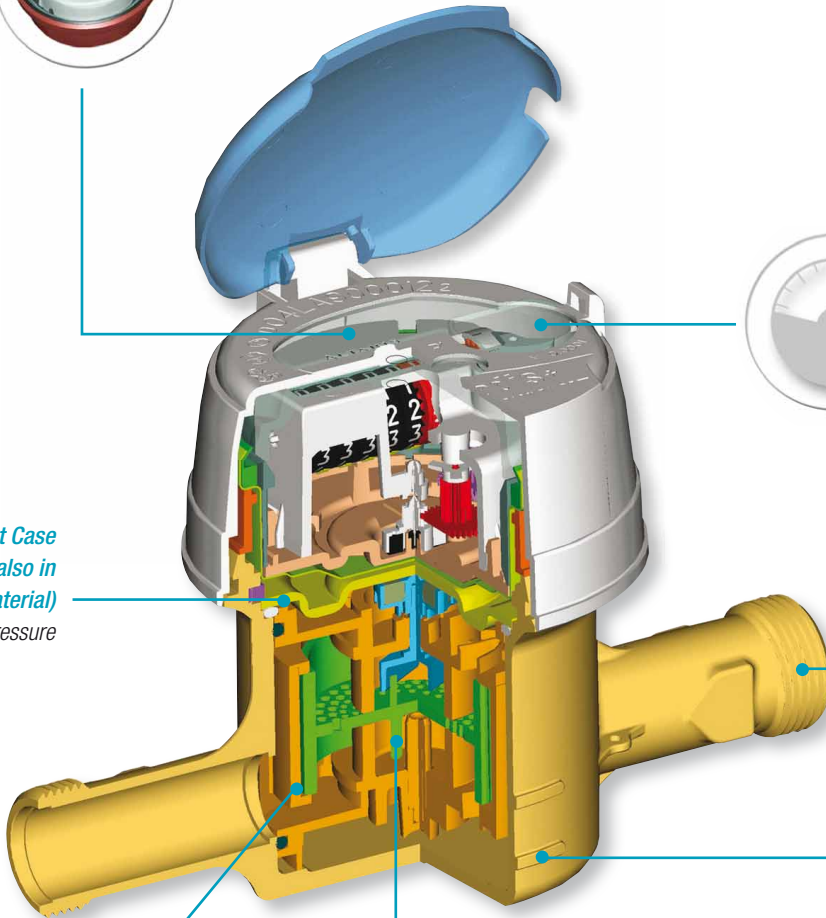

> Aquadis+ DN15

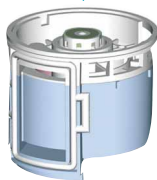

**Outstanding Accuracy and Long Term Performance**

Hydro-dynamically balanced piston obtained by an innovative design of measuring elements enables not only detection and account of extremely low flows (typically, < 1L/h) in wide range of flow rates, but also long-lasting and stable accuracy.

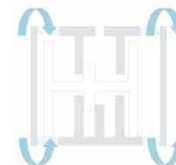

> Aquadis+ Register



**Option**

Aquadis+ meters may be fitted with:

- > Cyble modules from the factory (please refer to specific leaflet),
- > Non return-valve for outlet pipe,
- > Removable cap.

## Communication

**Aquadis+ is always pre-equipped with the proven Cyble technology**, making it possible to mount plug-and-play Cyble modules at any time. This opens up to a large range of advanced and reliable AMR systems:

- > Radio walk-by systems
- > Radio fixed data collection systems
- > M-Bus wired systems (walk-by or fixed network)
- > or any other system based on universal pulse outputs

### Key Advantages of Cyble Technology

- > Itron standard meter interface
- > No need of additional investments on the water meter
- > Electronic detection principle (no wear or bounce)
- > Leak detection
- > Reverse flow detection
- > Fraud detection
- > Not sensitive to magnetic fields
- > Perfect index correlation

*For further info, refer to the specific leaflet.*

## Typical Accuracy Curve according with R160 MID channel

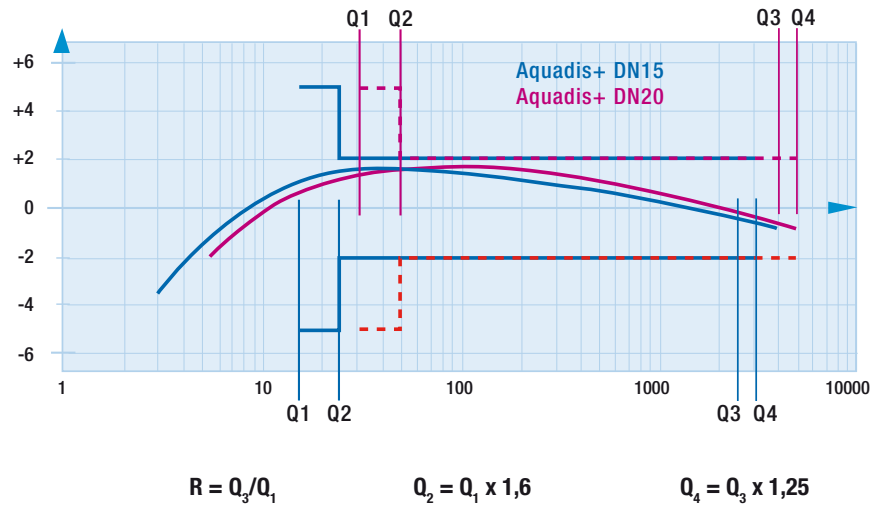

The dynamic range is defined as the Ratio (R) between the Nominal and the minimum flowrates. The MID approval proves the Aquadis+ real capacity to withstands to higher nominal flows ( $Q_3 > Q_n$ ).

## Head Loss

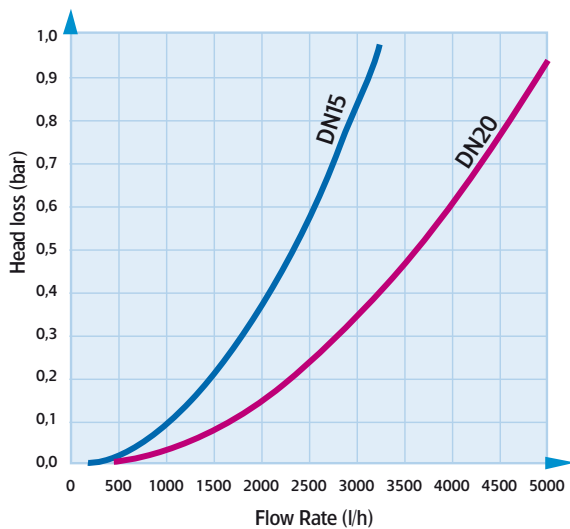

### > Cyble RF fitted on Aquadis+ DN15 meter



### > Aquadis+ DN20



### > Aquadis+ Manifold version



### > Aquadis+ DN15 composite version:

- robust
- lighter and ergonomic
- resistant to dezincification



Nominal diameter (DN)	mm inches	15		20
		1/2"	3/4"	3/4"

### In compliance with MID

MID Accuracy Ratio (Q3/Q1) - all positions			50 / 400		63 / 400
MID Type Approval Number			LNE 13636		LNE 16467
Nominal Flow Rate (Q3)	m <sup>3</sup> /h	1,6		2,5	2,5 / 4,0
Standard Ratio (*) (Q3/Q1)		100		160	100 / 160
Minimum Flow Rate (Q1)	l/h	16		15,6	25 / 25
Transitional Flow Rate (Q2)	l/h	25,6		25	40 / 40
Overload Flow Rate (Q4)	m <sup>3</sup> /h	2		3,125	3,1 / 5
Pressure Loss Class at Q3	bar	0,25		0,63	0,25 / 0,63
Maximum Admissible Pressure (MAP)	bar		16		16
Operating Temperature (T)	°C		0,1 / 30		0,1 / 50
Climatic Environment	°C		5 / 55		70 / -10

(\*) Other Ratios available under specific request

### Other Characteristics

Indication Range	m <sup>3</sup>		99999,999		99999,999
Minimum Scale Interval	l		0,02		0,02
Typical Starting Flow Rate	l/h		1		2
Accuracy +/- 5%	l/h		3		5
Accuracy +/- 2%	l/h		5		8
Testing Pressure	bar		25		25
Maximum Accidental Water Temperature	°C		50 (< 1h/day)		60 (< 1h/day)

### In compliance with EEC 75/33

EEC Metrology Class			Class C all position			-
EEC approval number			F-04-G-297			-
Nominal Flow Rate (Qn)	m <sup>3</sup> /h	0,75	1	1,5	0,75 / 1,5*	-
Maximum Flow Rate (Qmax)	m <sup>3</sup> /h	1,5	2	3	3	-
Minimum Flow Rate (Qmin)	l/h	7,5	10	15	7,5	-
Transitional Flow Rate (Qt)	l/h	11,25	15	22,5	11,25	-
Maximum Admissible Pressure (PN)	bar		16			-
Pressure Loss (Head Loss Group)	bar		1			-
Maximum Operating Temperature (T)	°C		30			-

### In compliance with British Standard 5728

BS Metrology Class			Class D all position			-
Nominal Flow Rate	m <sup>3</sup> /h		1	1,5		-
Maximum Flow Rate	m <sup>3</sup> /h		2	3		-
Minimum Flow Rate	l/h		7,5			-
Transitional Flow Rate	l/h		11,5			-

### Dimensions and Weight

Nominal Diameter	mm		15		20
Meter Thread	inches		G 3/4"		G 1"
	mm		20 x 27		26 x 34
A	mm	105 / 110 / 115*		130 / 165 / 190	190
B	mm		115		143
C	mm		22		20
D	mm		85		88
E	mm		68		70
F	mm		158		186
Weight in line	Kg		0,75 / 0,95		1,5
Weight coaxial	Kg		1,12		-

(\*) Other available lengths: 134, 165, 170

### > In line version

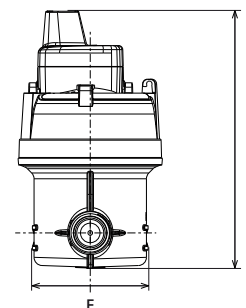
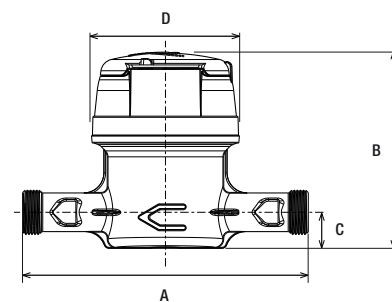

### > Manifold version

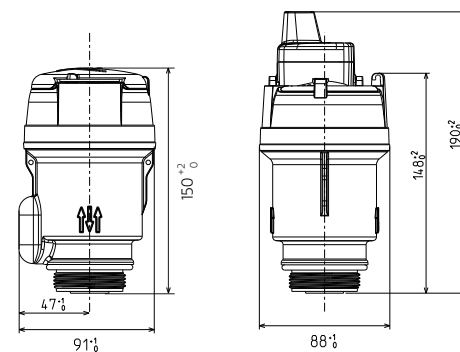

## About Itron Inc.

Itron Inc. is a leading technology provider to the global energy and water industries. Our company is the world's leading provider of metering, data collection and utility software solutions, with nearly 8,000 utilities worldwide relying on our technology to optimize the delivery and use of energy and water. Our products include electricity, gas and water meters, data collection and communication systems, including automated meter reading (AMR) and advanced metering infrastructure (AMI); meter data management and related software applications; as well as project management, installation, and consulting services. To know more, start here: [www.itron.com](http://www.itron.com)

For more information, contact your local sales representative or agency.

# Itron

9, rue Ampère  
71031 Mâcon cedex  
France  
Phone: +33 3 85 29 39 00  
Fax: +33 3 85 29 38 58  
[www.itron.com](http://www.itron.com)